

# ELECTROLINE

## ASSEMBLY INSTRUCTIONS

### 1400-Series Plugs for use with 3-Strand Rope

Electroline terminations have been used with ropes since 1933. The strength of the termination, ease of assembly, and the ability to inspect for proper termination, contribute to the continued acceptance of these fittings. Following these simple steps is your assurance of a durable installation. However, many factors determine the safety of any rope assembly. **PLEASE OBSERVE ALL USE AND CARE INSTRUCTIONS SUPPLIED WITH THE ROPE.**

#### RECOMMENDED TOOLS:

- Assembly Blocks\*
- Hammer
- Screwdriver
- Plug Driver\*
- Wrench
- Vise

#### ASSEMBLY KITS

Rope Size	Kit#
1/16-3/32"	SP-307-D
1/8-5/32"	SP-307-E
3/16-7/32"	SP-307-E
1/4-9/32"	SP-307-G
5/16"	SP-307-H
3/8"	SP-307-J
7/16"	SP-307-K
1/2"	SP-307-L
9/16"	SP-307-M
5/8"	SP-307-N
3/4"	SP-307-P

\*Assembly kits are recommended for easier and more efficient assembly of the fittings. The assembly block helps prevent damage to the rope during assembly. The plug drivers help seat the plug. The assembly kits are available from Electroline.

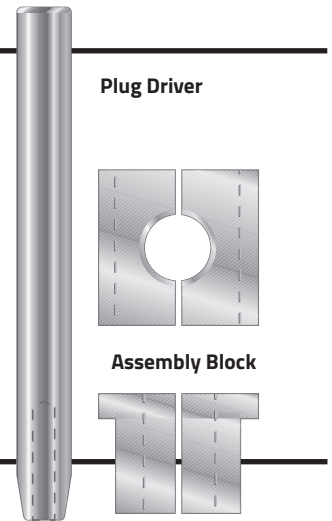

**STEP 1: Slide the sleeve over the rope, secure the rope in the assembly blocks and tighten the vise.** (Figure 1) If the Esmet assembly kit is not available, assembly blocks with a hole 1/32" less than the diameter of the rope can be made. If the rope has seizing, it may be easier to install the sleeve after the seizing has been removed. Before tightening the vise, be sure enough rope extends beyond the sleeve. (see dimensions in Figure 1).

Rope Size	B
1/16"	9/16"
3/32-1/8"	5/8"
5/32-3/16"	3/4"
7/32-1/4"	13/16"
9/32-5/16"	1"
3/8"	1-1/8"
7/16"	1-5/16"
1/2"	1-1/2"
9/16-5/8"	1-5/8"
3/4"	1-7/8"

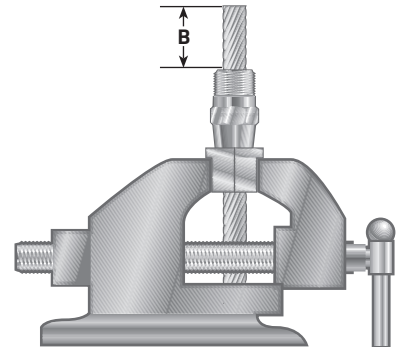

Figure 1

**STEP 2: Unlay the rope.** (Figure 2) Gently force a screwdriver between the three main strands to unlay the rope. Once the three main strands have been unlayed, insert the brass plug and partially seat the brass plug (this eliminates further unlaying of the strands). Now, unlay the wires in each of the three strands to form a symmetrical basket. Take care to minimize individual wires crossing each other in the symmetrical basket.

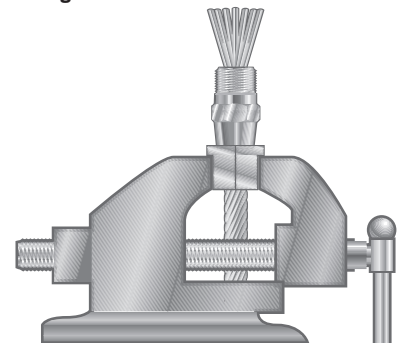

Figure 2

**STEP 3: Properly seating the plug.** With the plug in place from prior step, use a hammer and plug driver to pound the plug into the sleeve while assuring that the individual wires are spaced somewhat equally around the plug. Drive the plug until firmly seated and no more than 1/3 of the plug is visible above the sleeve.

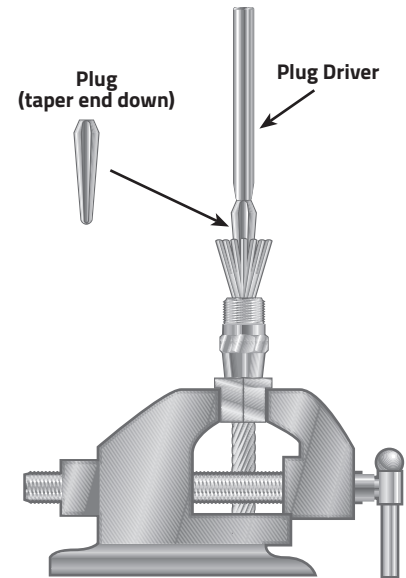

Figure 3

**STEP 4: Form the rope around the plug.** Re-clamp the assembly in the vise on the flat sides of the sleeve. Using the hole in the plug driver, bend the wires toward the center so the socket can be easily applied over all the wires.

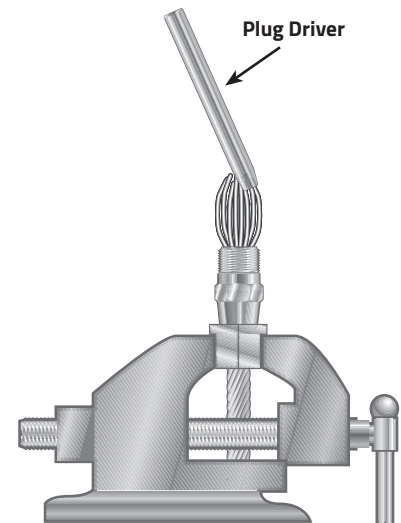

Figure 4

**STEP 5: Install the socket.** By twisting the socket over the wires, engage the threads and tighten until four or fewer threads are visible. When assembling, use an anti-seize lubricant, on the threads, to prevent any seizing in assembly. **Caution:** When assembling stainless steel parts, all threads must be coated with a dry film lubricant (MIL-L-23398) or an anti-seize lubricant (MIL-A-907) to prevent seizing. A lubricant may also ease in the assembly of fittings manufactured from other materials.

**STEP 6: Inspect for proper assembly.** (Figure 5) Prior to proof-loading, strands visible through the inspection hole are your assurance of a proper assembly. The end of the rope may not be visible in the inspection hole after proof-loading.

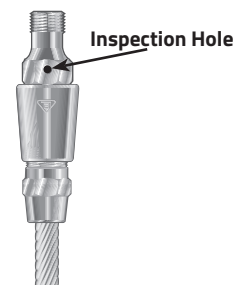

Figure 5

Most fittings are rated for 100% of EIP rope (for straight-line pull only). Please consult an Electroline sales associate or review the Electroline catalog for specification information. Rarely do applications require a fastening device (i.e. set-screw, Loctite®, lock-wire, etc.) to retain the sleeve in the socket. The socket can be removed from the sleeve at any time for inspection and will not affect the holding efficiency of the sleeve and plug. However, a new plug is necessary if the rope is re-terminated. Periodically inspect the socket for tightness.